



PR-101/102 STEREO PREAMPLIFIER
Phono Preamp
ASSEMBLY MANUAL

© 2017-2023 Akitika LLC
All rights reserved.
Revision 2p06 September 17, 2024

Table of Contents

Table of Contents	2
Table of Figures	2
Section 1: About This Manual	3
Who Should Attempt this Project?	3
Tools you'll need	3
Helpful Tools	4
Project Overview	4
Important Safety Notes	4
About Components	4
Recommended Solder	5
Warranty	5
Section 2: Kit Building Hints.....	5
Section 3: Building the Phono Preamp	5
Component Order.....	6
Install the Resistors	6
Install the small non-polarized capacitors.....	8
Install the bypass capacitors.....	8
Install the Selector Jumpers	9
Install the Integrated Circuits.....	10
Install film capacitors.....	10
Install the Electrolytic (polarized) Capacitors	11
Install the Power Wires.....	11
Install the Signal Wires.....	12
Install Connectors and Front Panel.....	13
Install Mounting Brackets.....	14
Section 5: Configure the Options.....	14
Cartridge Loading	14
High-Pass Filter Setting	15
Gain Setting	16
Section 5 – Install the Phono Preamp into the PR-101/2.....	17
Mechanical Installation.....	17
Power Connections	17
Signal Connections	18
Section 6: Tests and Final Assembly	19
Section 7: Hooking Up a Turntable	19
Grounding notes.....	19
Knurled Nut Contact to the Ground wire.....	20
Section 8: About the Phono Preamp	20
Specifications.....	20
Appendix 1 – Shielded Cable Preparation	21

Table of Figures

Figure 1-Empty the phono preamp components into a soup bowl	6
---	---

Figure 2-Silk screen shows phono preamp component locations	6
Figure 3-Locating pin 1 of the IC and pin 1 of the PCB.....	9
Figure 4-Prepare 12" length of Red/Black Zip cord (drawing not to scale)	11
Figure 5-Close-up showing installation of power, ground and signal wires	12
Figure 6-Hardware detail for installing the RCA Jacks and insulating washers into the faceplate	13
Figure 7-Install both jacks, noting orientation of ground lugs, color stripes, and solder terminal	14
Figure 8-Install the mounting brackets	14
Figure 9-No additional capacitive loading is selected with the short plugs as shown here	14
Figure 10-Left Channel and Right Channel High Pass Jumpers	15
Figure 11-P6 sends left channel gain, P5 sets right channel gain	16
Figure 12-Phono stage installed but power and signal not yet routed and connected	17
Figure 13-Additional Grounding Wire may be needed	20
Figure 14-Schematic Page 1 of 2	23
Figure 15-Schematic Page 2 of 2	24

Section 1: About This Manual

This manual gives the information needed to build and use the moving magnet phono preamplifier for Akitika LLC's PR-101 or PR-102 Stereo Preamplifier.

- The original phono preamplifier was produced for a number of years and is described in the 1pXX series of manuals. The schematics are found in a link on the website. It was built on a PCB listed as Rev B4.
- The latest version of the phono preamplifier is described in the 2pXX manuals. The design is essentially unchanged. This latest version was produced as some of the precision capacitors previously used were no longer available in the same footprint. The PCB is listed as Rev C1 (with 2 white wires) or Rev C2 (no white wires)..

Who Should Attempt this Project?

You can build this kit if you can:

1. Solder (using normal rosin core solder and a soldering iron).
2. Use simple hand tools like screwdrivers, wire cutters, and pliers.
3. Read and follow directions.

It helps if you:

1. know a bit about electronics, or
2. have a friend who knows a bit about electronics
3. can get to YouTube to watch a few helpful videos about the assembly process (none are posted as of this version of the manual).

Tools you'll need

You'll need the following tools:

1. Phillips screwdriver (#1 and #2)
2. Pliers or nut drivers suitable for #4 and #6 hardware

3. needle nose pliers (helpful, but not strictly necessary)
4. pencil type soldering iron of 25 to 50 Watts (no huge honking soldering guns or blowtorches)
5. wire cutters and strippers
6. multi-meter to measure power supply voltages and confirm resistor values (strongly recommended)!

Helpful Tools

These tools aren't strictly necessary, but make building the kit easier.

1. magnifying glass, if you're over 42!
2. lead bending jig to form axial component leads for PCB insertion.

Project Overview

The project consists of the following steps:

1. Building the phono preamp circuit board.
2. Configuring the loading, gain, and highpass options.
3. Installing the phono preamp into a PR-101 preamplifier.

Important Safety Notes

By purchasing, using, or assembling this kit, you have agreed to hold Akitika LLC harmless for any injuries you may receive in its assembly and/or use. To prevent injuries:

- Wear safety glasses when soldering or clipping wires to prevent eye injuries.
- Always unplug the power before working on the amplifier.
- Large capacitors hold lots of energy for a long time. Before you put your hands into the amplifier:
 - Pull the AC plug!
 - Wait 2 full minutes for the capacitors to discharge!
- Remove jewelry and rings from your hands and wrists, or anything that might dangle into the amplifier.
- If working on the equipment with the power on, keep one hand in your pocket, especially if you're near the power supply or power supply wires. This can prevent serious shocks.
- Build with a buddy nearby. If you've ignored all the previous advice, they can dial 911 or get you to the hospital.
- Read and understand the safety manuals of all the tools you use.

About Components

We reserve the right to make design/or component changes at any time without prior notification.

Recommended Solder

The kit must be assembled with either 63/37¹ or 60/40 Rosin Core solder. The recommended diameter is about 0.031 inches. Among many such sources of solder, I have used Radio Shack part number 64-009. It contains 8 oz. of solder, which is much more than you'll need to assemble the PR-101 kit. More recently, I have used Kester 24-6337-8800 50 Activated Rosin Cored Wire Solder Roll, 245 No-Clean, 63/37 Alloy, 0.031" Diameter.

Warranty

With the exception of fuses, Akitika will replace for free any parts of a correctly assembled product that fails within one year of the date of purchase when the equipment has been used in home stereo applications. It is the responsibility of the kit builder to install the replacement part(s). This warranty applies to the original purchaser only. It does not apply to units that have been physically or electrically abused, modified without prior factory authorization, or assembled with other than 60/40 Rosin Core solder. Akitika LLC's liability shall in no event exceed the cost paid to Akitika LLC for the kit.

Section 2: Kit Building Hints

Yes, I know you want to ignore this section, and jump right into building the kit. However, please **take a minute and read the advice of this section.** I've condensed it into bullets so that even you guys who are in a hurry can benefit.

- Stop any time you're feeling confused, tired, or anxious. Taking breaks at those strategic times will keep the build enjoyable and greatly enhance your chances of first-time success.
- A soup bowl is your friend. Before you build a board, carefully empty the parts into a broad, flat, light colored soup bowl. That makes it easy to find the parts, and keeps them from getting lost.
- A digital ohm-meter is an easy way to make sure that you've picked the right resistor. It's a great cross-check on the resistor color code. Measure twice and solder once!
- A lead-bending jig can make for quicker, neater assembly. It's certainly not necessary.
- Is something in this manual confusing? Does something look wrong? Send your questions by email to dan@akitika.com. You'll help yourself and everyone who builds the kit.

Section 3: Building the Phono Preamp

This section details the process of building the phono preamp circuit board. Begin by carefully emptying the contents of the parts envelope into a broad soup bowl, as shown below. In general, you'll start with the components that lay closest to the board, working your way towards the taller components.

¹ 63/37 is preferred over 60/40 solder.

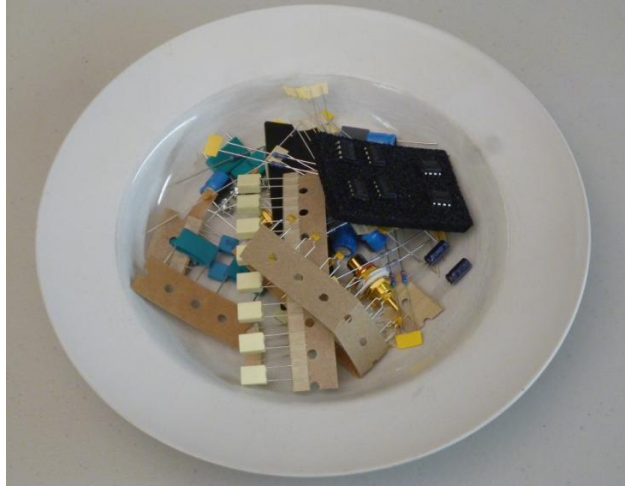

Figure 1-Empty the phono preamp components into a soup bowl

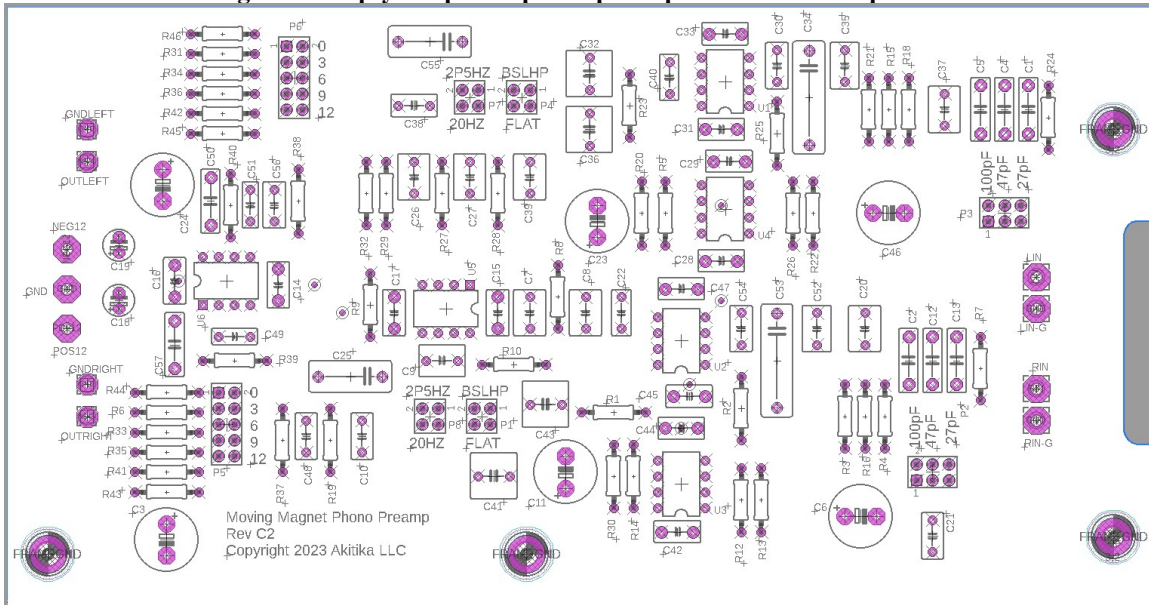

Figure 2-Silk screen shows phono preamp component locations

Component Order

You'll notice that the component designations in the directions don't go exactly in order. We have grouped them so that all components with the same value appear together. This makes assembly easier. You'll find in the parts kit that similar parts, e.g. 3 1K resistors, are typically (though not always) taped together.

Install the Resistors

In general, you install axial leaded components (like the resistors) by placing the body on the silk screen side of the board, and the leads through the indicated holes. Bend the leads over on the back of the board to keep the resistors from falling out until your solder them in place. Try to bend the leads in a direction that won't lead to solder bridges between traces that should remain disconnected.

We recommend the following procedure:

1. Insert all components of the same value or type
2. Bend the leads as described above.
3. Solder the leads on the back of the board.
4. Clip the leads.

Track your progress by placing a check-mark in the done column as you install each component.

Bend resistor leads to 0.40" width			
Designation	Value	Color Code	Done ✓
R43	1K	Brown, Black, Black, Brown, Brown	
R44	1K	Brown, Black, Black, Brown, Brown	
R45	1K	Brown, Black, Black, Brown, Brown	
R46	1K	Brown, Black, Black, Brown, Brown	
R6	1K18	Brown, Brown, Grey, Brown, Brown	
R19	1K18	Brown, Brown, Grey, Brown, Brown	
R31	1K18	Brown, Brown, Grey, Brown, Brown	
R32	1K18	Brown, Brown, Grey, Brown, Brown	
R15	1M00	Brown, Black, Black, Yellow, Brown	
R16	1M00	Brown, Black, Black, Yellow, Brown	
R3	221	Red, Red, Brown, Black, Brown	
R20	221	Red, Red, Brown, Black, Brown	
R21	221	Red, Red, Brown, Black, Brown	
R30	221	Red, Red, Brown, Black, Brown	
R37	23K2	Red, Orange, Red, Red, Brown	
R38	23K2	Red, Orange, Red, Red, Brown	
R39	24K9	Red, Yellow, White, Red, Brown	
R40	24K9	Red, Yellow, White, Red, Brown	
R22	2K00	Red, Black, Black, Brown, Brown	
R12	2K00	Red, Black, Black, Brown, Brown	
R13	2K00	Red, Black, Black, Brown, Brown	
R26	2K00	Red, Black, Black, Brown, Brown	
R9	31K6	Orange, Brown, Blue, Red, Brown	
R29	31K6	Orange, Brown, Blue, Red, Brown	
R41	412	Yellow, Brown, Red, Black, Brown	
R42	412	Yellow, Brown, Red, Black, Brown	
R5	4K22	Yellow, Red, Red, Brown, Brown	
R14	4K22	Yellow, Red, Red, Brown, Brown	
R35	590	Green, White, Black, Black, Brown	
R36	590	Green, White, Black, Black, Brown	
R2	5K23	Green, Red, Orange, Brown, Brown	
R25	5K23	Green, Red, Orange, Brown, Brown	
R10	5K62	Green, Blue, Red, Brown, Brown	
R27	5K62	Green, Blue, Red, Brown, Brown	
R1	63K4	Blue, Orange, Yellow, Red, Brown	

R23	63K4	Blue, Orange, Yellow, Red, Brown	
R33	825	Grey, Red, Green, Black, Brown	
R34	825	Grey, Red, Green, Black, Brown	
R8	8K06	Grey, Black, Blue, Brown, Brown	
R28	8K06	Grey, Black, Blue, Brown, Brown	
R4	---	This position is not populated	
R18	---	This position is not populated	
R7	---	This position is not populated	
R24	---	This position is not populated	
R11	Not present	Not part of either schematic or PCB	
R17	Not present	Not part of either schematic or PCB	

Note: save some of the longer cut resistor leads. You'll use them in one of the final assembly steps to connect the RCA jacks to the PCB.

Install the small non-polarized capacitors

The capacitors you'll install in this section can be installed in either orientation. Please leave C22 and C40 for last in this section.

Small Value COG dielectric Capacitors			
Designation	Value	Rating, Marking, Description	Done? (✓)
C2	100 pF	COG, 101K, axial leads	
C5	100 pF	COG, 101K, axial leads	
C50	100 pF	COG, 101K, axial leads	
C57	100 pF	COG, 101K, axial leads	
C13	27 pF	COG, 270K, axial leads	
C1	27 pF	COG, 270K, axial leads	
C4	47 pF	COG, 47J, axial leads	
C12	47 pF	COG, 47J, axial leads	
C22	10 pF	COG, 100, blue radial leaded package	
C40	10 pF	COG, 100, blue radial leaded package	

Install the bypass capacitors

The 0.1 μ F bypass capacitors are not polarized, and can be inserted with either orientation.

Non Polarized Bypass Capacitors (Location Hint: a pair of these surrounds each IC)			
Designation	Value	Rating, Marking	Done? (✓)
C14	0.1 μ F	Bypass, 104, radial leads	
C15	0.1 μ F	Bypass, 104, radial leads	
C16	0.1 μ F	Bypass, 104, radial leads	
C17	0.1 μ F	Bypass, 104, radial leads	
C28	0.1 μ F	Bypass, 104, radial leads	
C29	0.1 μ F	Bypass, 104, radial leads	
C31	0.1 μ F	Bypass, 104, radial leads	
C33	0.1 μ F	Bypass, 104, radial leads	
C42	0.1 μ F	Bypass, 104, radial leads	

C44	0.1 μ F	Bypass, 104, radial leads	
C45	0.1 μ F	Bypass, 104, radial leads	
C47	0.1 μ F	Bypass, 104, radial leads	

Install the Selector Jumpers

Install the selector pin fields using the following check-list. Hint: Begin by soldering just one corner pin to make sure the pin-field sits straight and level. That makes it easy to re-heat and adjust the pin-fields if they're a bit crooked. Once the pin fields are straight, solder the remainder of the pins.

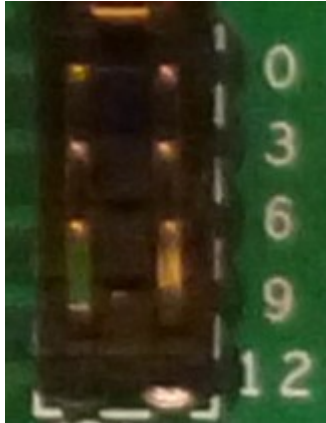

Selector Pin Fields		
Designation	Description	Done? (✓)
P2	3x2 pin field for left channel cartridge loading. Insert the short side into the PCB.	
P3	3x2 pin field for right channel cartridge loading. Insert the short side into the PCB.	
P1	2x2 pin field. Insert the short side into the PCB.	
P4	2x2 pin field. Insert the short side into the PCB.	
P7	2x2 pin field. Insert the short side into the PCB.	
P8	2x2 pin field. Insert the short side into the PCB.	
P5	2x5 pin field. Insert the short side into the PCB.	
P6	2x5 pin field. Insert the short side into the PCB.	

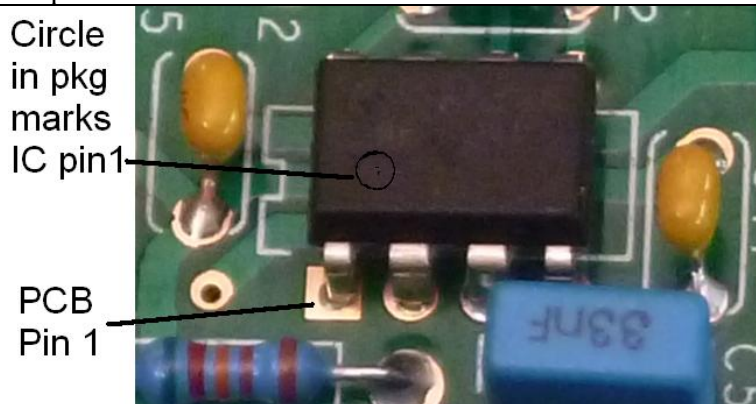

Figure 3-Locating pin 1 of the IC and pin 1 of the PCB

Install the Integrated Circuits

Integrated Circuits (watch pin 1 location)		
<i>Note: U1 and U2 are 5534. U3-U6 are 5532's. They are different! Please don't get them confused!</i>		
Designation	Description	Done? (✓)
U1	NE5534 single opamp, 8 pin dip package	
U2	NE5534 single opamp, 8 pin dip package	
U3	NE5532 dual opamp, 8 pin dip package	
U4	NE5532 dual opamp, 8 pin dip package	
U5	NE5532 dual opamp, 8 pin dip package	
U6	NE5532 dual opamp, 8 pin dip package	

Install film capacitors

Nonpolar Film Capacitors			
Designation	Value	Rating, Marking, Description	Done? (✓)
C51	0.1 μ F	Film, 100n, small box, radial leads	
C49	0.1 μ F	Film, 100n, small box, radial leads	
C38	0.33 μ F	Film, .33J63, radial leads	
C10	0.33 μ F	Film, .33J63, radial leads	
C7	1 μ F	Film, 1J63, radial leads	
C8	1 μ F	Film, 1J63, radial leads	
C9	1 μ F	Film, 1J63, radial leads	
C20	1 μ F	Film, 1J63, radial leads	
C26	1 μ F	Film, 1J63, radial leads	
C27	1 μ F	Film, 1J63, radial leads	
C37	1 μ F	Film, 1J63, radial leads	
C39	1 μ F	Film, 1J63, radial leads	
C21	10 nF	Film, 10nJ100, radial leads, some kits may have 10nK400 caps instead	
C32	100 nF	Big Black Film cap, 100 nF, 160V, radial leads	
C36	100 nF	Big Black Film cap, 100 nF, 160V, radial leads	
C41	100 nF	Big Black Film cap, 100 nF, 160V, radial leads	
C43	100 nF	Big Black Film cap, 100 nF, 160V, radial leads	
C56	2.2 nF	Film, 2n2, radial leads	
C48	2.2 nF	Film, 2n2, radial leads	
C55	2.2 μ F	Film, 2.2J63, radial leads	
C25	2.2 μ F	Film, 2.2J63, radial leads	
C34	22 nF	Film, 22n, radial leads	
C53	22 nF	Film, 22n, radial leads	
C35	3.3 nF	Film 3n3J100, radial leads	
C52	3.3 nF	Film 3n3J100, radial leads	
C54	33 nF	Film, 33nF, radial leads	
C30	33 nF	Film, 33nF, radial leads	

Install the Electrolytic (polarized) Capacitors

Polarized Capacitors (watch polarity)			
Designation	Value	Rating, Marking	Done? (✓)
C3	220 μ F	Electrolytic capacitor, 220 μ F 35 V, radial leads	
C11	220 μ F	Electrolytic capacitor, 220 μ F 35 V, radial leads	
C6	220 μ F	Electrolytic capacitor, 220 μ F 35 V, radial leads	
C23	220 μ F	Electrolytic capacitor, 220 μ F 35 V, radial leads	
C24	220 μ F	Electrolytic capacitor, 220 μ F 35 V, radial leads	
C46	220 μ F	Electrolytic capacitor, 220 μ F 35 V, radial leads	
C18	22 μ F	Electrolytic capacitor, 22 μ F 35 or 50V, radial leads	
C19	22 μ F	Electrolytic capacitor, 22 μ F 35 or 50V, radial leads	

Install the Power Wires

Prepare a 12" length of red/black zip cord as shown below. Twist the ends tightly, and tin them.



Figure 4-Prepare 12" length of Red/Black Zip cord (drawing not to scale)

Prepare a 12" length of 18 AWG Green wire. Twist and tin the ends as shown here:



Power Wiring	
Task	Done? (✓)
Insert Red wire of Red/black pair into component side of PCB hole marked POS12V in TB1. Solder on the solder side.	
Insert black wire of Red/black pair into component side of PCB hole marked NEG12V in TB1. Solder on the solder side.	
Insert green wire into component side of PCB hole marked GND in TB1. Solder on the solder side.	

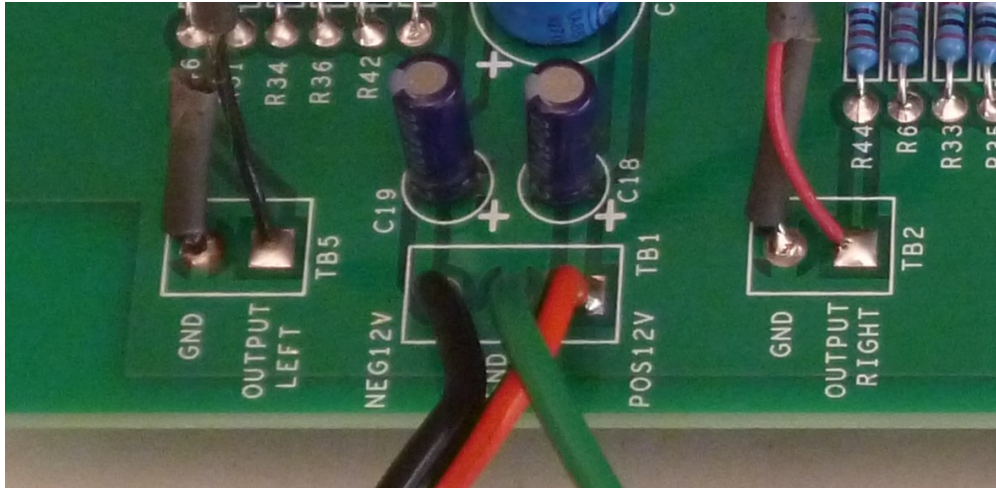

Figure 5-Close-up showing installation of power, ground and signal wires

Install the Signal Wires



Signal Wiring (Right Channel Connections)	
Task	Done? (✓)
Cut a 6" length of shielded cable that will be used for the right channel connections.	
Prepare the ends as shown in Appendix 1. Reserve the outer jacket removed when you exposed the ends.	
Cut the black wire at both ends of the shielded cable.	
Strip, twist and tin the remaining red ends (2 places)	
Twist and tin the drain wire at both ends.	
Cut a ½" length of the outer jacket and slip it over the drain wire.	
Insert the red wire into the component side of the PCB, into the OUTRIGHT terminal.	
Insert the drain wire (with the outer jacket covering) into the component side of the PCB, into the GNDRIGHT terminal.	



Signal Wiring (Left Channel Connections)	
Task	Done? (✓)
Cut a 6" length of shielded cable that will be used for the left channel connections.	
Prepare the ends as shown in Appendix 1. Reserve the outer jacket removed when you exposed the ends.	
Cut the red wire at both ends of the shielded cable.	
Strip, twist and tin the remaining black ends (2 places)	
Twist and tin the drain wire at both ends.	
Cut a ½" length of the outer jacket and slip it over the drain wire.	
Insert the black wire into the component side of the PCB, into the OUTLEFT terminal.	
Insert the drain wire (with the outer jacket covering) into the component side of the PCB, into the GNDLEFT terminal.	

Install Connectors and Front Panel

Install the RCA jacks into the faceplate using the details of Figure 6 and Figure 7.

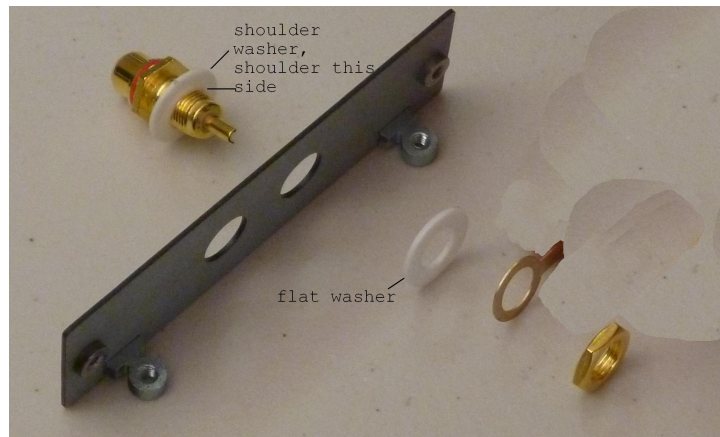

Figure 6-Hardware detail for installing the RCA Jacks and insulating washers into the faceplate

Jack Installation	
Task	Done? (✓)
Install the jacks using insulating washers as shown in Figure 6 and Figure 7. Note that the locations of the RED and BLACK rings on the RCA jacks. We recommend installing the left (black) RCA jack first for easier assembly.	
Fasten the faceplate to the PCB using two 4-40x1/4" sem screws (they have a built-in lockwasher) as shown in Figure 7.	
Complete the jack wiring as shown in Figure 7, a total of 4 wires. Use spare ends from resistor and capacitor leads to make the connections.	



Figure 7-Install both jacks, noting orientation of ground lugs, color stripes, and solder terminal

Install Mounting Brackets

Install the two mounting brackets using 6-32x1/4" sem screws as shown in Figure 8.



Figure 8-Install the mounting brackets

Section 5: Configure the Options

Cartridge Loading

Capacitive loading of the cartridge changes its frequency response. Typical RCA phono cables have a capacitance of about 17 pF/foot. You can add to this capacitance by selecting jumpers on P2 and P3.

As an example, the Shure M97E is said to have improved sound with 200 pF of loading. Given 3 foot cables, there would be 51 pF of loading from the cables. You'd then add another 147 pF, for a total of 198 pF to optimize its loading.



Figure 9-No additional capacitive loading is selected with the short plugs as shown here

The additional capacitive loading is the sum of the selected values:

Total Additional Loading (pF)	100 pF	47 pF	27 pF
0	Not selected	Not selected	Not selected
27	Not selected	Not selected	selected
47	Not selected	selected	Not selected
74	Not selected	selected	selected
100	selected	Not selected	Not selected
127	selected	Not selected	selected
147	selected	selected	Not selected
174	selected	selected	selected

Notes:

1. To select a capacitor, install the shorting plug to bridge both terminals on a line with the capacitance designation.
2. Recommended default: 100 pF
3. To *not* select a capacitor, install the shorting plug to only contact one terminal on a line with the capacitance designation, that terminal being the one farthest from the capacitance designation. See Figure 9.

All the shorting plugs will be used, even if some of the shorting plugs for capacitor loading are in the storage position (described in 3 above) rather than the active position.

High-Pass Filter Setting

A turntable can generate extreme low frequency signals that really aren't part of the music. Depending on your turntable, amp, and speakers, it may be beneficial to reduce some of this extreme low frequency information. The following table shows the jumper settings and the various low frequency responses that they produce.

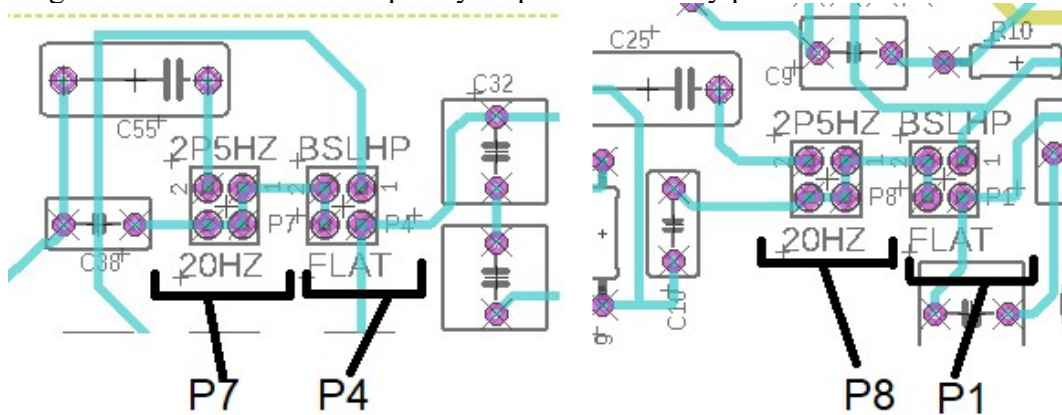

Figure 10-Left Channel and Right Channel High Pass Jumpers

P7 (and P8) give a highpass response that is:

- -3 dB at 20 Hz when the bottom two pins are connected by a shorting plug.
- -3 dB at 2.5 Hz when the top two pins are connected by a shorting plug.

P4 and P1 further modify the highpass response:

- Not at all, e.g. this filter is flat, when the bottom two pins are connected by a shorting plug.
- By adding a 3rd order Bessel Filter that is -3 dB at 20 Hz (and quite a bit farther down at the critical warp region below 10 Hz) when the top two pins are connected by a shorting plug.

You must install one shorting plug in each of P1, P8, P4, and P7 for proper operation.
Recommended Defaults:

- P7 in the top spot, choosing 2.5 Hz high pass filter.
- P4 in the top spot, choosing BSLHP (Bessel High Pass Filter)
- P8 in the top spot, choosing 2.5 Hz high pass filter.
- P1 in the top spot, choosing BSLHP (Bessel High Pass Filter)

Gain Setting

This phono preamp was made to use with moving magnet cartridges. Moving magnet cartridges provide around 5 mV at 5 cm/sec at 1 kHz, and are meant to be loaded by 47 K Ohms.

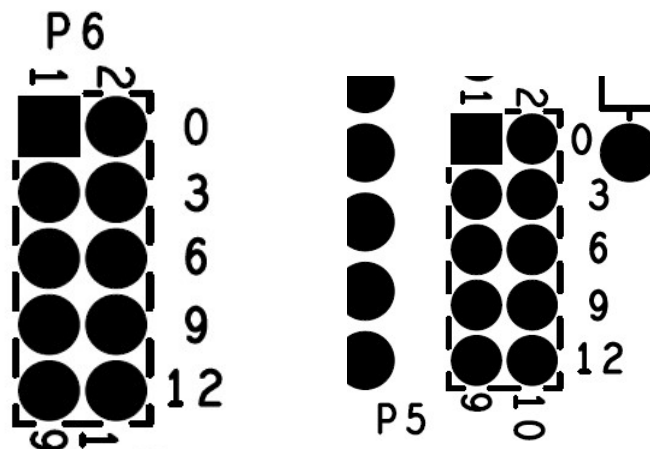

Figure 11-P6 sends left channel gain, P5 sets right channel gain

It's hard to say what gain setting will be best for your system in advance. In general, it's best to use the lowest gain setting that provides adequate volume for your equipment and listening situation.

You must install one shorting plug in each of P5 and P6 for proper operation.
Recommended Defaults:

- P5 in the 3 dB position
- P6 in the 3 dB position

We recommend using the 3 dB setting of P5 and P6 as a starting point. If, with this setting, you find that the volume control is cramped toward the low-end, you can change to the 0 dB setting. If the volume control is too far toward the high end, you can change to gain settings of 6, 9, or 12 dB.

It is possible to access and change all of the options after the phono preamp has been installed without removing the phono preamp.

Section 5 – Install the Phono Preamp into the PR-101/2

Make sure that the power is disconnected from the PR-101/2 before proceeding with the installation.

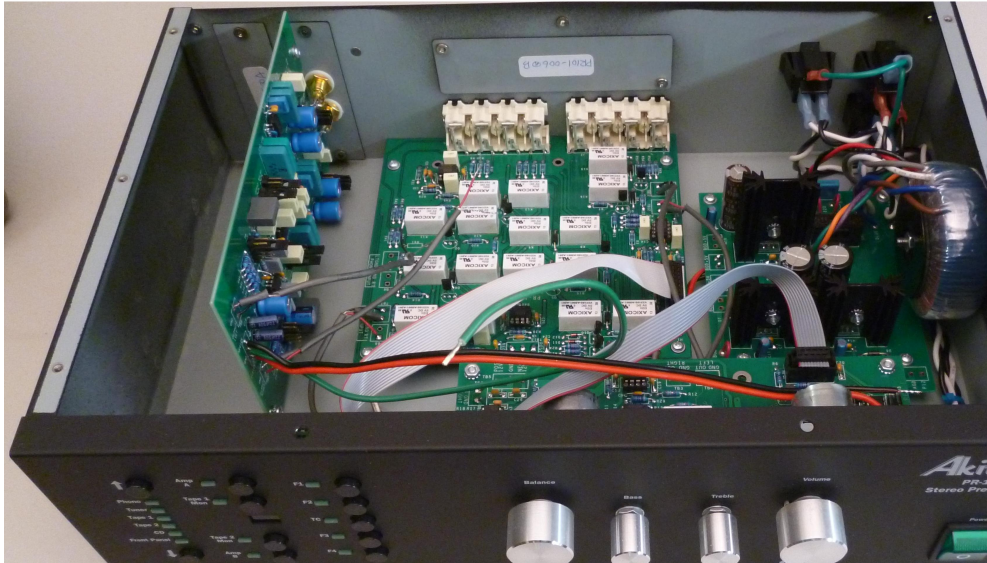

Figure 12-Phono stage installed but power and signal not yet routed and connected

Mechanical Installation

Please protect the paint finish on your PR101/2. Be sure to put a towel onto your work surface prior to laying your PR101/2 on your work bench.

Remove the cover plate from the Exp 1 Slot and save the two mounting screws. Butt the phono preamp faceplate to the inside of the front panel. Line up the two mounting holes in the back panel with those in the phono preamp faceplate. Hold the phono preamp in place using the two mounting screws that previously held the cover plate.

Fasten the two mounting brackets to the bottom of the chassis using two 6-32x1/4" sem screws, inserted from the bottom of the chassis into the mounting brackets.

Power Connections

Connecting +/-12V power to the phono preamp can be done without removing the power supply board from the PR-101/2. In a previous step, you tinned the power wires. This makes it easy to solder them into the power supply PCB. Insert the wires from the component side, leaving about 1/8" of un-insulated wire above the PCB. This leaves room to apply the tip of the soldering iron simultaneously to the PCB lands and the wire, so the solder will melt and a good connection formed.

You can select any of the unused +/-12 terminal sets on the power supply board. We recommend using TB1. If you followed the PR-101 Assembly instructions, TB3 and TB4 are already used.

- Please note the following
1. Use the recommended order, installing green wire first to minimize damage to adjacent power wires as you solder them in place.
 2. Remove the end of the control cable where it connects to the tone volume board and fold it out of the way to avoid damaging it with your soldering iron.
 3. While soldering, keep the wires straight as they approach the board. This will keep the insulation from peeling back as you solder.

Power Wiring	
Task	Done? (✓)
Insert the green wire into component side of the power supply PCB into the PCB hole marked AGD on TB1. Solder from the component side.	
Route the Red/Black pair and the green wire from the phono preamp power connector (TB1) along the chassis floor, next to the stand-offs for the tone/volume board, on the front panel side of the stand-offs.	
Insert Red wire of Red/black pair into component side of the power supply PCB into the PCB hole marked P12 on TB1. Solder from the component side.	
Insert black wire of Red/black pair into component side of the power supply PCB into the PCB hole marked N12 on TB1. Solder from the component side.	

Signal Connections

Right Channel Signal Wiring	
Task	Done? (✓)
Locate the shielded cable coming from the right channel output of the phono preamp. It has a red wire and a drain wire.	
Cover the drain wire with a ½” length of the previously reserved outer jacket. Insert the bare end of the drain wire into the component side of TB6’s GND pin on the input selector board and solder it in place from the component side.	
Insert the bare end of the red wire into the component side of TB6’s RT pin on the input selector board and solder it in place from the component side.	

Left Channel Signal Wiring	
Task	Done? (✓)
Locate the shielded cable coming from the left channel output of the phono preamp. It has a black wire and a drain wire.	
Cover the drain wire with a ½” length of the previously reserved outer jacket. Insert the bare end of the drain wire into the component side of TB5’s GND pin on the input selector board and solder it in place from the component side.	
Insert the bare end of the black wire into the component side of TB5’s LT pin on the input selector board and solder it in on the component side.	

Section 6: Tests and Final Assembly

Check the plus and minus 12 volt supplies to assure that they are still within tolerance. This is a quick sanity check for (mostly) correct assembly of the phono preamp.

Remove power.

Replace the cover and re-install the eleven screws that retain the cover.

Connect power again and make sure the PR101 goes through its familiar power-up sequence. You can now begin hooking up to your turntable.

Section 7: Hooking Up a Turntable

Connect Left channel from the turntable to the left channel (black ring) input using high quality RCA jacks. Connect right channel from the turntable to the right channel (red ring) input using high quality RCA jacks. Make sure that the ground crowns fit snugly to get lowest hum and noise.

Grounding notes

If your turntable has a separate ground wire (most do, but there are some notable exceptions...the Orbit basic turntable and the Acoustic Research XA turntable don't have separate ground wires) make sure to tighten it down under the knurled nut on your PR101/2's back panel.

The knurled nut on the PR101/2 back panel, the chassis ground, is connected to green wire ground. Green wire ground connects to circuit ground through the front panel 1/8" phono jack. That connection is only needed for hum control when using low level inputs like a phono. On occasion, that connection has been somewhat tenuous.

You can check for a connection between chassis ground and signal ground by connecting an ohm-meter between the ground shells of the RCA jacks and the knurled-nut chassis ground. If there isn't a low resistance connection, then you may have to add one to get low hum from the connected phono.

The best place to do this is from the chassis ground behind the power switch to the AGD connection right behind it on the power supply. Use the lug, 18 AWG green wire, and one of the 6-32 nuts supplied in the auxiliary grounding kit. Note: the grounding stud will now have two lugs and two nuts. This makes sure that the green wire ground will always be connected to the chassis.

In some grounding arrangements, it may be preferable to add 100 Ohms in series with the ground wire shown in Figure 13. Some experimentation may be needed to arrive at the lowest noise setup for your particular equipment.

Knurled Nut Contact to the Ground wire

Depending upon the thickness of the spade lug or wires on your turntable's ground wire, it may not make a good connection to the stud using just the knurled nut. In that case, first install a 6-32 nut (supplied in the auxiliary grounding kit) onto the grounding stud, tighten it, and leave it in place. Then place the knurled nut on top. The ground wire will then be held securely between the 6-32 nut and the knurled nut.

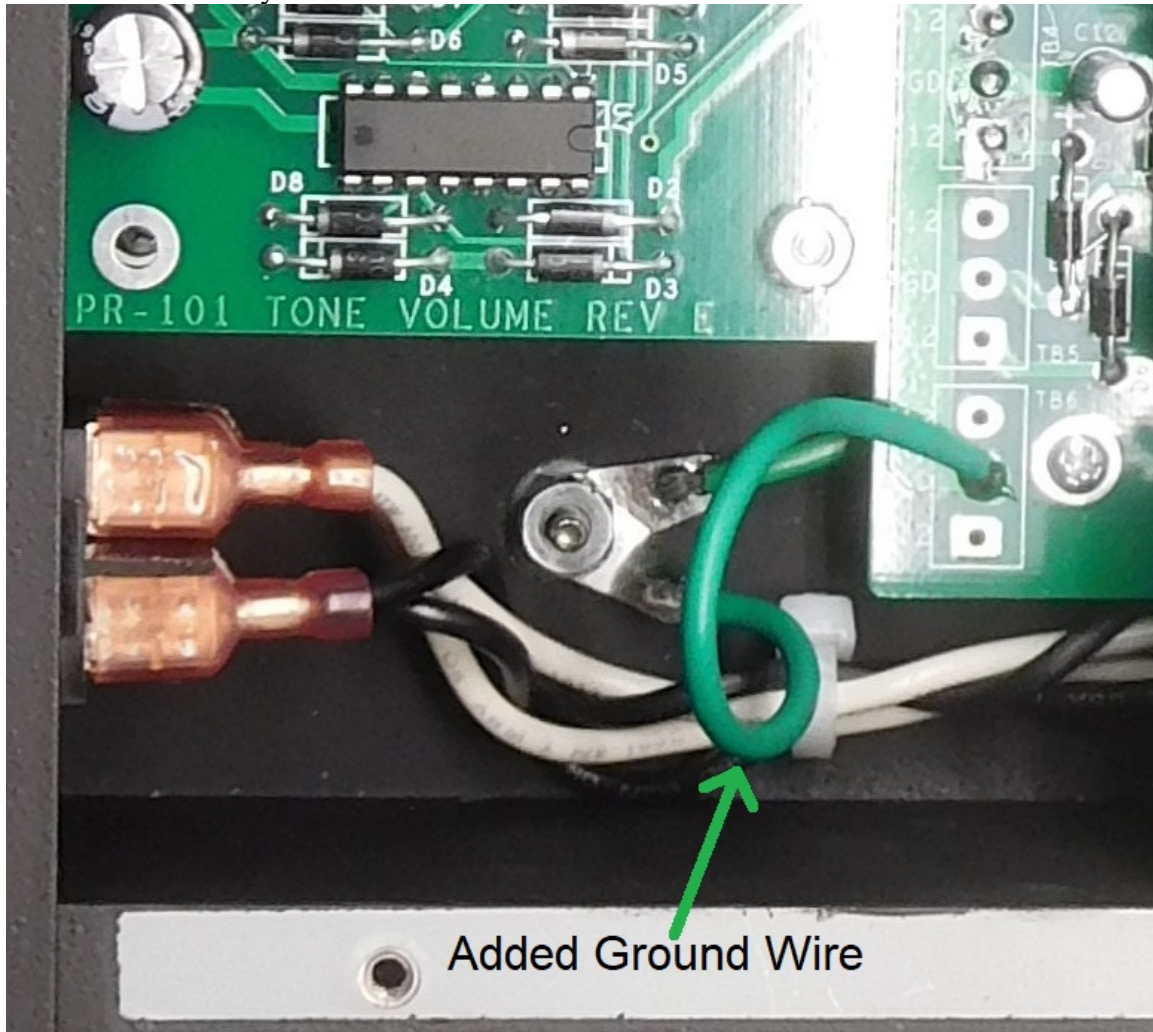

Figure 13-Additional Grounding Wire may be needed

The PR101 phono preamp is very quiet. Any hum generated will originate on the RCA cords and from the phono cartridge external to the PR101. If you'd like more ways to get the best possible hum performance, please visit this link for more information.

<http://theobjectiveturntable.com/HumStrategies.html>

Section 8: About the Phono Preamp

Specifications

- Output impedance - 1000 Ohms

- Distortion –
 - all harmonics more than 100 dB down for inputs of less than 150 mV rms at 1 kHz, with gain set to 3 dB
 - all harmonics around 120 dB down for 10 mV input at 1 kHz, with gain set to 3 dB
- Gain at 1 kHz (30, 33, 36, 39, or 42 dB, jumper selectable)
- High Pass Filter settings:
 - -3 dB at 20 Hz
 - Flat (-3 dB at around 2.6 Hz, -0.5 dB at 20 Hz)
 - 3rd order Bessel Highpass (-3 dB at 20 Hz)
 - 3rd order Bessel Highpass (-3 dB at 20 Hz) plus additional first order filter that is -3 dB at 20 Hz) for total response that is -6 dB at 20 Hz
- Noise (A Weighted) - TBD
- RIAA Accuracy – typically +/- 0.1 dB (neglecting high pass filters)
- Selectable loading – 0, 27, 47, 74, 100, 127, 147, 174 pF
- Power supply requirements - +/-12V, 40 mA from each rail (idle)

Appendix 1 – Shielded Cable Preparation

This section tells how to prepare the end of a shielded cable.

1. Cut the shielded cable to the overall required length.



2. Use a utility knife with a new, sharp blade to cut the plastic jacket of the shielded cable 1" back from the end. Hold the blade perpendicular to the cable, and draw it across the cable lightly as you rotate the cable along its long dimension. This creates a scored line through the plastic jacket. With a sharp blade, not much pressure is needed. You may need a bit of practice to get the feel.



3. If you've scored the jacket carefully, you can separate the jacket at the score line without using tools. Pull the insulating jacket off, exposing the cable, showing the foil shield, the drain wire, and the fuzzy string. The result is shown here, with the foil shield showing.



4. Cut off the fuzzy string.



5. Separate and twist the drain wire.

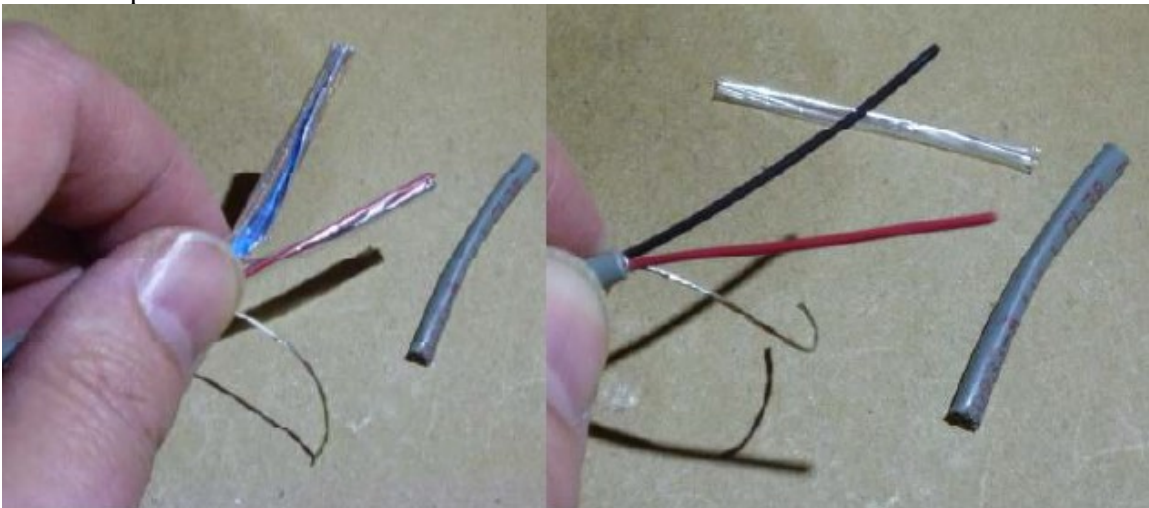

6. Peel back and remove the foil. Remove the plastic wrap from the red and black wires. The drain (bare wire), red, and black wires are exposed now that gray insulating jacket, foil shield, and plastic over-wrap have been removed.
7. Save the gray outer jacket as it will be used (perhaps cut to half length) to insulate the bare drain wire.

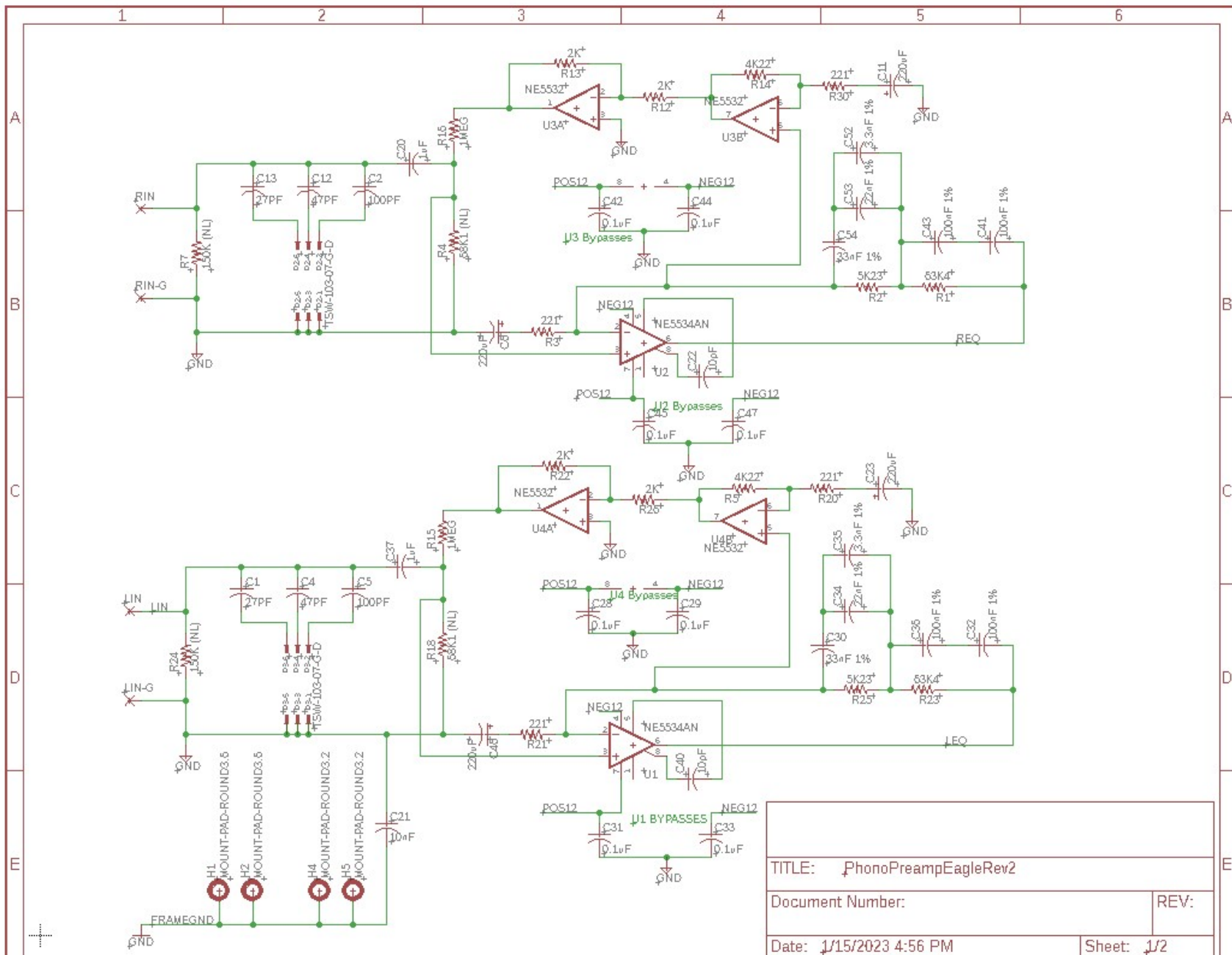
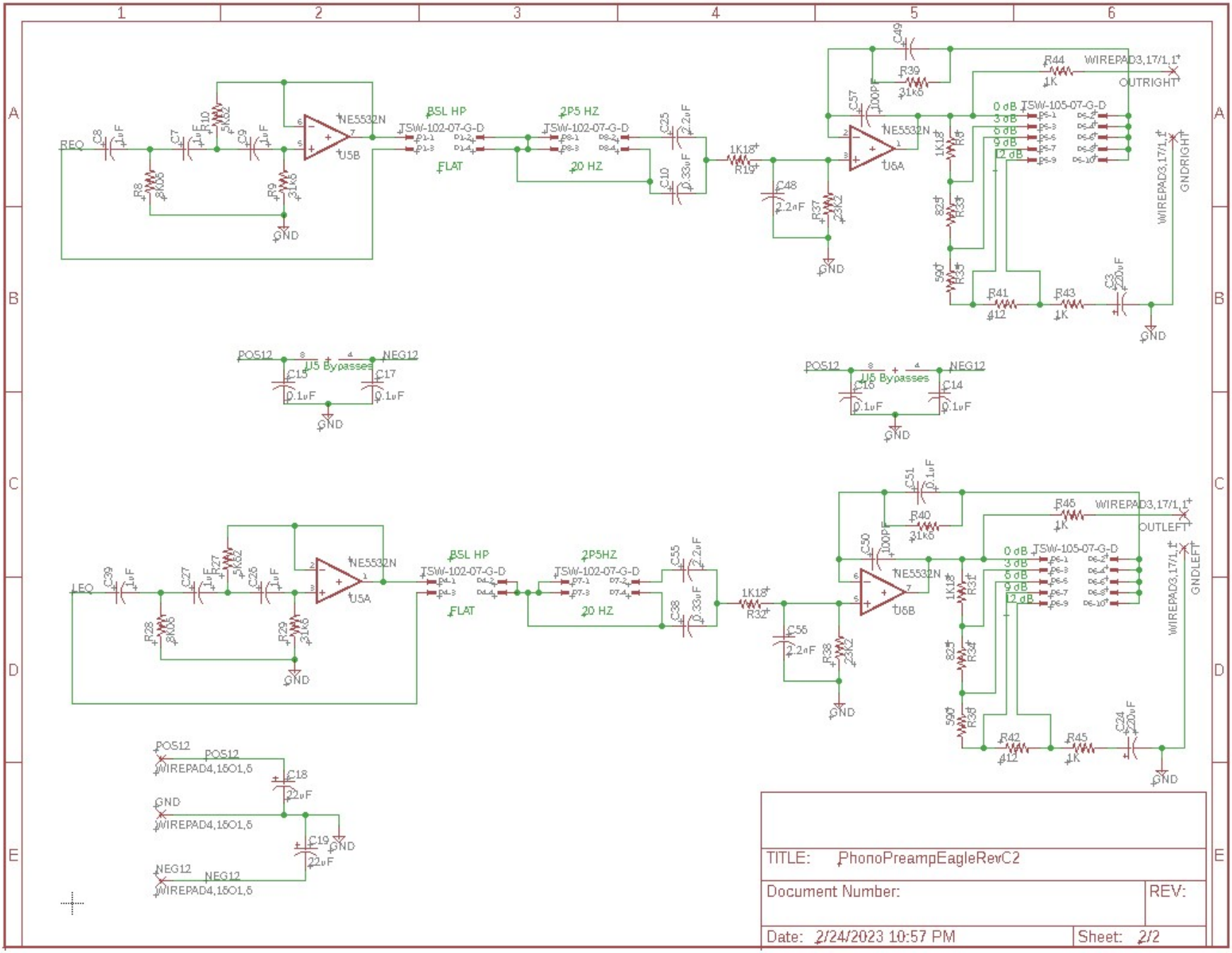

Figure 14-Schematic Page 1 of 2



TITLE: PhonoPreampEagleRevC2	
Document Number:	REV:
Date: 2/24/2023 10:57 PM	Sheet: 2/2

Figure 15-Schematic Page 2 of 2